

Dellmecco[®]

www.dellmecco.com



DELLMECO is a leading pump manufacturer since 2004.

We manufacture Air Operated and Electro-mechanical Operated Double-Diaphragm Pumps (AODD and EODD Series) with a wide range of accessories for industrial use.

We also offer state-of-the-art design and development in our new factory premises, supported by our internationally recognised ISO/TUV Quality Management System.

Leading-edge technology and engineering expertise combined with our extensive know-how ensure consistent high quality of our product range to meet our Customers' expectations.

DELLMECO aims for the best quality supported by R&D to meet the demands of modern pumping applications. Our goal is to stay 'Out in Front' as the market leader.

- 1.** To be the 'best pump manufacturer' in the world.
- 2.** High Corporate Social Responsibility (CSR).
- 3.** Operate through a network of partners and co-operating distributors.
- 4.** Set-up distribution centers in strategic locations/countries.
- 5.** Continue with strong innovation and R&D support.



KEY FEATURES OF ALL DELLMECO PUMPS

Manufacturing carried out in our modern factory – under 'one roof' enables us to respond quickly to customer/market demands

Unique, compact and versatile design combining high-tech with proven reliability and quality

Low air consumption Air Operated option and energy saving **Electro-mechanical** drive options.

Wide range of applications and specialised designs for liquids, powders, abrasive and/or corrosive media

SEMI series designed especially for ultra high purity chemicals such as used in the semiconductor and pharmaceutical industries

Housings machined from PE, PTFE, conductive PE and PTFE (Plastic Series Pumps), machined casts from Aluminium, Cast Iron, AISI 316 (Metal Series Pumps) and stamped parts (Hygienic Series Pumps).

Designed to operate within a temperature range from -40 to +200 degrees Celsius

Can be installed in hazardous areas with explosion proof designs (ATEX)

'Out in Front' of the industry standards: self-priming, can run dry without heat build-up or wear, adjustable flow by simple air/frequency regulation, long life diaphragms for heavy duty applications (no diaphragm discs), operating without lubrication or seals

Easy, preventive maintenance planning' (PMP) and minimum maintenance costs



Plastic Series

chemicals, food and beverage,
electro-plating, paper manufacturing



Hygienic Series

pharmaceutical, food and beverage
cosmetics



Metal Series

chemicals, ceramics, petro-chemical
minerals and mining, environmental



SEMI Series

semiconductor, pharmaceutical
ultra-high purity



DMCX Series

dedicated for painting industry



Plastic DME Series

electro-mechanical series
for multiple applications



Hygienic DME Series

electro-mechanical series
for multiple applications



Accessories

pump optional equipment

NEW SERIES



DM SXTT-X
interchangeable valve seats



DMU Series
sides, central body
and connectors integrated



Aseptic Series
sanitary standards
for design and fabrication



DMF Series
compact unit with integrated pulsation dampener,
for smooth pumping



DMR Series
designed for submerged operation

MATERIALS:

PE, PTFE, conductive PE and PTFE

INDUSTRY:

chemicals, food and beverage, electro-plating, paper manufacturing

MODEL SIZE:

DM 08/10

DM 10/25

DM 15/55

DM 25/125

DM 40/315

DM 50/565

DM 80/850



MAIN FEATURES:

Designed to succeed

- temperatures up to + 120°C
- pressure up to 14 bar g
- lubrication-free operation
- low air consumption
- abrasion resistance (PE, PE conductive)

Flexible installation

- BSP as standard
- PN10, PN16, ANSI, NPT, JIS, RJT, split manifold configurations available
- connections may rotate 180°

Solid, compact and strong

- housing machined from solid PE, PTFE as well as conductive PE and PTFE
- withstands aggressive chemicals
- gentle pumping action
- viscous media transfer

Perfect diaphragm

- completely smooth liquid-side surface (no holes)
- no metal in contact with the media
- materials made to match the application



MATERIAL:

AISI 316L

INDUSTRY:

pharmaceutical, food and beverage, cosmetics

MODEL SIZE:

DM 15/30

DM 25/75

DM 40/125

DM 50/315

DM 65/565

DM 80/850



MAIN FEATURES:

Designed to succeed

- temperatures up to 120°C
- pressure up to 14 bar g
- lubrication-free operation
- low air consumption
- smooth surface in contact with liquid

Quick dismantling

Clamping system enables rapid dismantling without tools

Plain surface

The “sandwich” diaphragms has a plain surface which eliminates problems associated with microbial growth. The diaphragms are available in food grade material – pure TFM (PTFE).

Superior finish

Both the media side and outside are electro-polished to obtain a superior hygienic finish. Other special surface finishes may be carried out according to requirements.

Variety of connection types

The pump is supplied as standard with connectors according to DIN 11851. However, it can be equipped with almost any type of connections used in the hygienic sector such as TriClamp, SMS, RJT, JIS or ANSI.

Designed for C.I.P and S.I.P systems

Cleaning-In-Place (CIP) and Sterilisation-In-Place (SIP) are designed for automatic cleaning and disinfection without major dismantling of the pump.



MATERIALS:

Aluminium, Cast Iron, Stainless Steel (AISI 316 and 316L)

INDUSTRY:

*chemicals, ceramics, petro-chemical
minerals and mining, environmental*

MODEL SIZE:

DM 15/25

DM 20/75

DM 25/125

DM 40/315

DM 50/565

DM 80/850



MAIN FEATURES:

Designed to succeed

- temperatures up to + 120°C
- pressure up to 14 bar g
- lubrication-free operation
- low air consumption

Flexible installation

- BSP as standard
- PN10, PN16, ANSI, NPT, JIS, RJT, split manifold configurations available
- connections may rotate 180°

Solid, compact and strong

- housings from Aluminium, Cast Iron AISI 316 and AISI 316L castings
- withstands aggressive chemicals
- gentle pumping action
- viscous media transfer

Perfect diaphragm

- completely smooth liquid-side surface (no holes)
- no metal in contact with the media
- materials made to match the application

AVAILABLE OPTIONS:



ALUMINIUM + PTFE
with AISI 316 CONNECTIONS



ALUMINIUM



AISI 316
AISI 316L (on demand)



CAST IRON

MATERIALS:

TFM/PTFE, UPPE, Stainless Steel centre housing (AISI 316L)

INDUSTRY:

semiconductor, pharmaceutical, ultra high purity

MODEL SIZE:

DMS 10

DMS 20

DMS 50

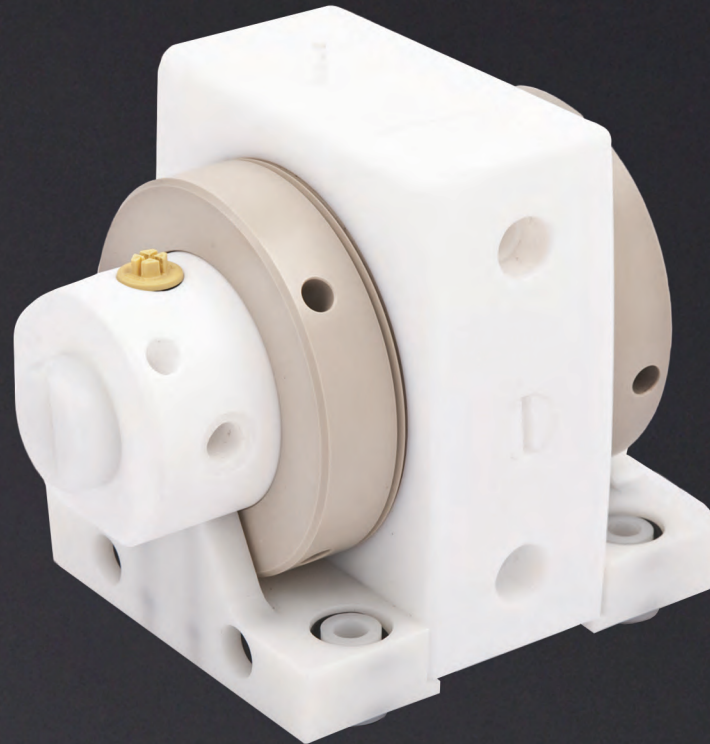

MAIN FEATURES:

1. PTFE/UPPE with no metal parts (even down to atomic scale).
2. No elastomer o-ring seals and no lubrication.
3. Class 100 Clean Room assembly.
4. **3 sizes** of PTFE/UPPE for acids and caustics
- up to 130°C (SEMI T).
5. **2 sizes** of PTFE for hot applications with acids and caustics
- up to 200°C (SEMI H).
6. **3 sizes** of UPPE for slurries (SEMI E).
7. **2 sizes** centre housing of stainless steel for solvents (SEMI S).
8. Pressure up to 6 bar g.

AVAILABLE OPTIONS:



MATERIAL:

Conductive PE

INDUSTRY:

dedicated for painting

MODEL SIZE:

DMCX 10

DMCX 20

DMCX 50

DMCX 130

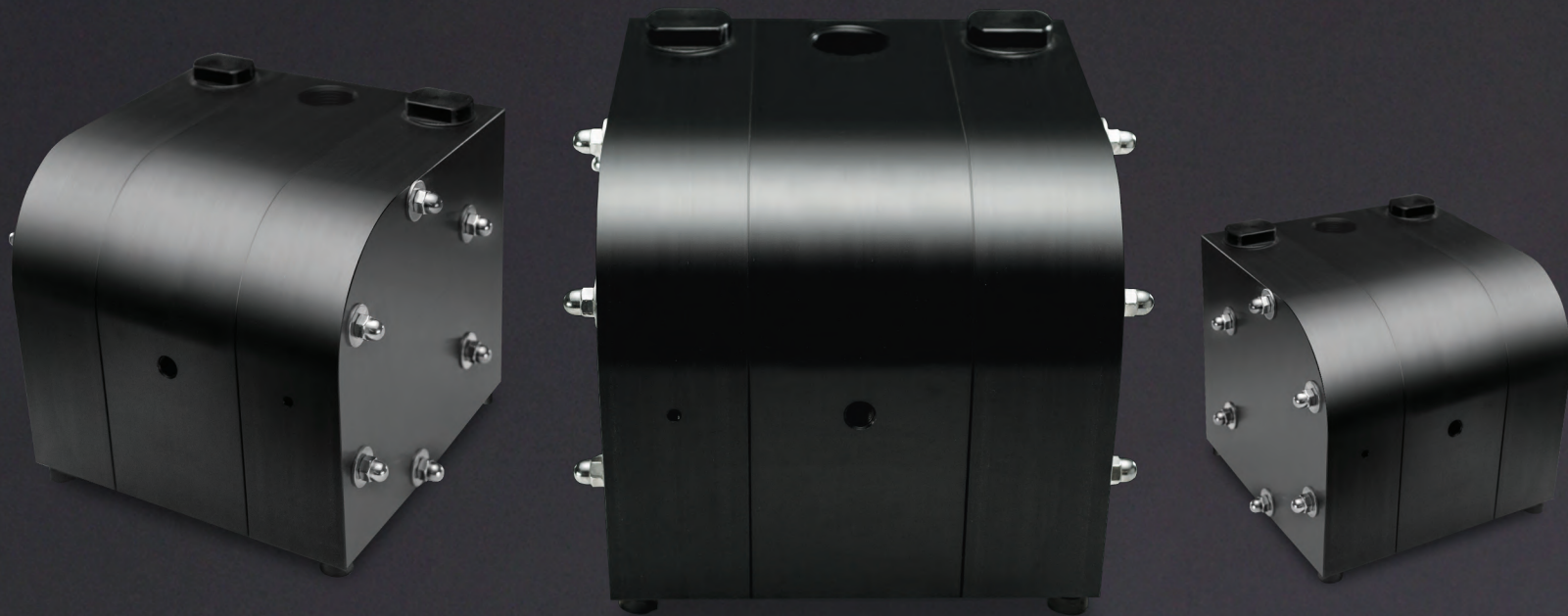

MAIN FEATURES:

- **pneumatic diaphragm pumps** for pumping small to medium volumes of media
- **machined from solid material** on highly advanced Computer Numerical Control (CNC) Machining and Turning Centers
- **driven by compressed air** (no need for electric motors or electrical connections)
- **4 pump sizes** with media capacities from 10-130 l/min (water at 20°C)
- **air control system** without lubrication or 'dead' spot
- diaphragms made of **EPDM, NBR or PTFE(TFM) / EPDM composite**
- **ball or cylinder valves** available
- **self-priming**
- **easy preventive maintenance**
- **made of conductive PE** (with ATEX conformity)
- **compact design, less spare parts**



Electro-mechanical double diaphragm

MODEL SIZE:

DME 15

DME 20

DME 25

DME 40

DME 50

DME 65

DME 80

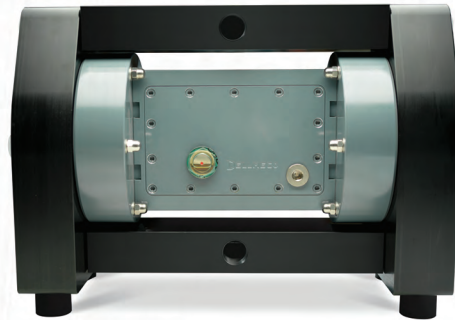

PLASTIC SERIES

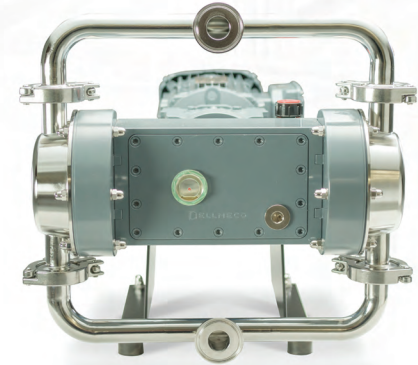
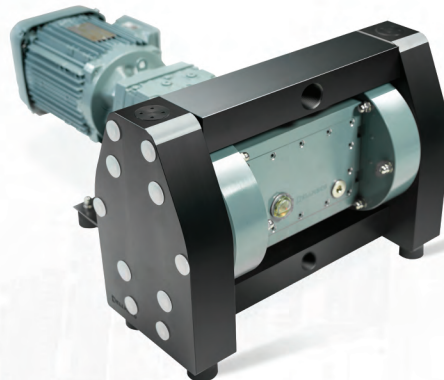

HYGIENIC SERIES

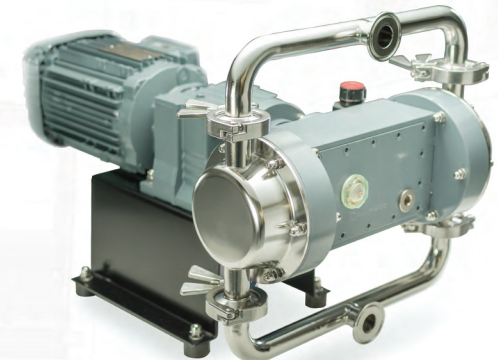

MAIN FEATURES:

1. **Pump elements** from: conductive PE, conductive PTFE, aluminium, cast iron, AISI 316 and AISI 316L
2. **7 sizes** available:
 - flow capacity from 25 – 835 l/min
 - electric motors from 0.75 – 9.2 kW/3 phase
 - bare shaft (BS) option available
3. **Temperature applications** up to 120°C
4. **Easy flow control** by Variable Frequency Drive (VFD)
+ Push Button Stop (PBS1 and 3) for pressure control
5. **Dry running, low shear** (for shear sensitive media), wide range of applications
6. **Low energy consumption**
7. Easy PMP and minimum maintenance costs





MAIN FEATURES

Pumps from the plastic series in ATEX version are specially designed devices compliant with the European Union's ATEX directive. The ATEX directive sets essential requirements for products intended for use in explosive atmospheres. Thanks to this, these pumps ensure safe and reliable operation even in challenging conditions, providing protection against potential explosion risks.



NEW PUMP DESIGN

- Interchangeable valve seats -

DM 20/75 SXTT-X
25/125 SXTT-X

1. Leakproofness test at **8.2 bar**
2. Dry suction height: **3.2 mWC / 4.8mWC**
3. Ball valve seats tightness **100%**





NEW AODD DMF SERIES

Compact unit with integrated pulsation dampener,
for smooth pumping

- manufactured from machined conductive PE
- lubrication-free operation
- in-/outlet connection size BSP ½
- maximum temperature up to 70°C
- second product chamber can be used
as an extractor or circulation pump
- available size: DMF 15/10 R

NEW AODD DMU SERIES

Sides, central body and connectors integrated

- compact design, main parts integrated
- easy maintenance – no housing bolts
- less sealing areas
- no upper/lower plugs
- available in two sizes: „DMU 08” and „DMU 10”





NEW AODD DMR SERIES

Excellent for emptying bottom tanks

- PE conductive material execution
- designed for submerged operation
- longitudinal shape allows the pump to be placed inside the pipe
- available in two sizes: „DMR 08” and „DMR 10”

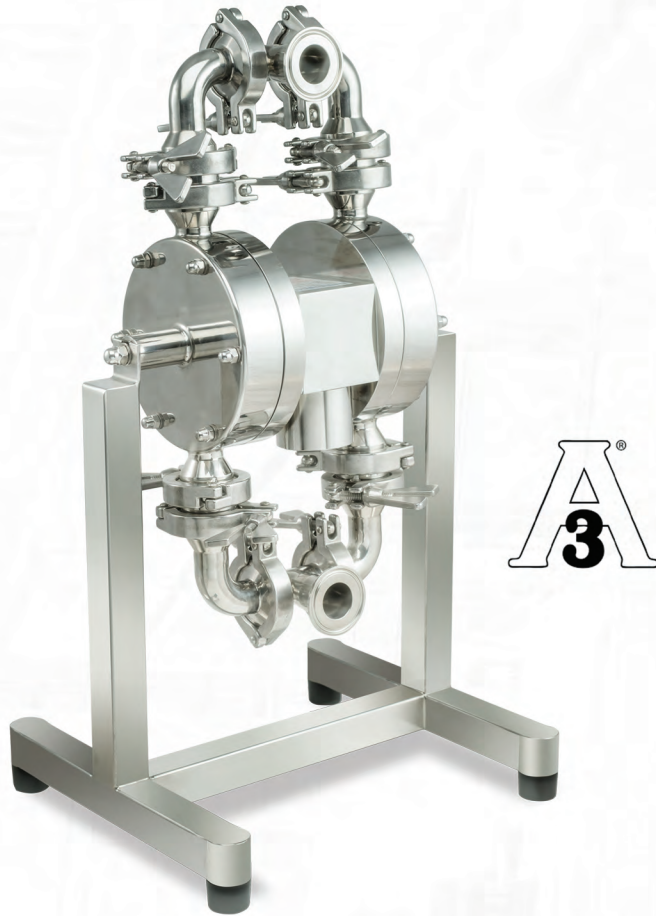

NEW ASEPTIC SERIES

AISI 316L Sanitary standards for design and fabrication

- designed and approved for 3A
- less bacteria growing areas
- easy to clean and disassemble
- approved for „Clean-In-Place” and „Sterilization-In-Place” processes



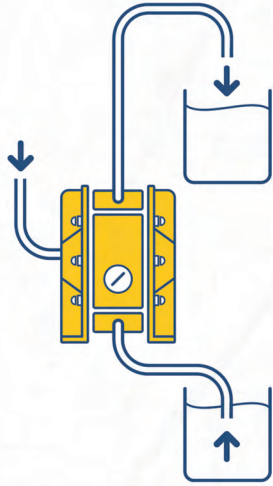

SELF-PRIMING APPLICATION

The suction lift range is up to 8 meters. This will vary according to construction materials and application parameters. All data are based upon pumping water at 20°C

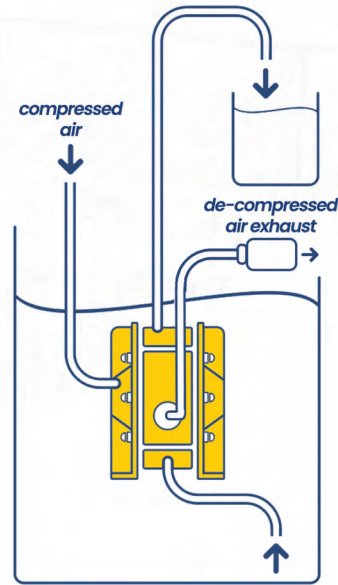

SUBMERGED OPERATION

Our pumps can operate under full submersion (not applicable for MV option and all DME Pumps). The construction materials must be suitable for the surrounding liquid and the outlet must be positioned above the liquid level.

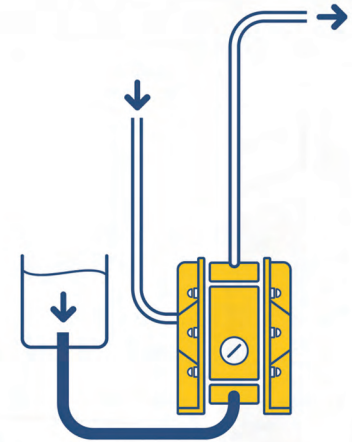

POSITIVE SUCTION HEAD

As a method for completely emptying holding tanks, clarifiers or similar containers. Optimum inlet pressure should be kept at 0.2-0.3 bar g.

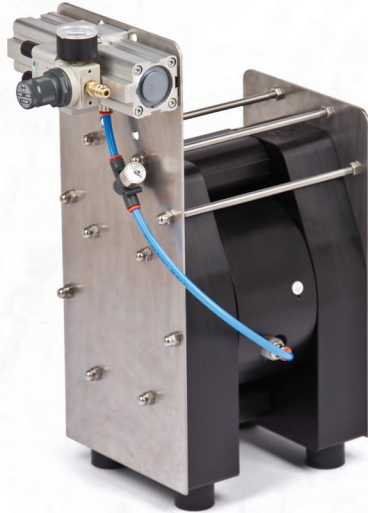

High pressure plastic pump with booster (HP option)

The high pressure (HP) option is a compact booster that can be directly mounted to the pump. It is capable of doubling the delivery pressure and, for example, with an available air pressure of 7 bar the pressure can be up to 14 bar.

The design is based upon the standard DELLMECO pump made from machined polyethylene (PE). A pressure regulator is already incorporated with the unit for easy adjustment.

Applications include filter presses and slurry drying especially in the food and beverage industry as well as for water and wastewater management.

- self-priming
- easy preventive maintenance
- made of conductive PE (with ATEX conformity)



Plastic pump with solenoid valve (MV option)

DELLMECO plastic pumps with the MV option replace the standard air valve with a solenoid air valve. This enables media to be delivered in precise and constant volumes for such applications as found in the chemical industry.

The pump is fitted to a 2-position, 4-way solenoid valve. When the solenoid is unpowered, one chamber within the pump is pressurised with air, whilst the opposite chamber is discharged. When electric power is applied, the solenoid re-pressurises the discharged chamber and the opposite chamber is then discharged.

By alternatively turned on and off, the solenoid enables the unit to run like a standard DELLMECO pump and no lubrication is needed.

This option requires 24 V DC to operate.
Pumps with the MV option are non-submersible.

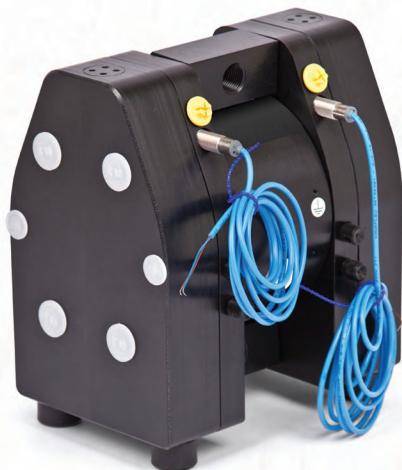

Barrier chamber system (BC option)

To comply with increased safety standards, this system replaces the standard diaphragm by a tandem arrangement of two diaphragms and a PE conductive barrier chamber filled with a non-conductive liquid (usually de-ionized water).

Sensors monitor the conductivity of this liquid and if the diaphragm fails, they detect the change in conductivity and an electric signal is sent to a controller.

The barrier system is available with three options:

- BC1 – barrier system with sensors, standard
- BC2 – barrier system complete with sensors and controllers
- BC3 – barrier system complete with sensor and controllers for explosion-proof zones – ATEX



Stroke counting (SC options)

A sensor is installed in the central pump housing to count the strokes. The diaphragm shaft is scanned without physical contact by this sensor – ensuring safe monitoring totally independent of external influences and the pump's mode of operation. The signal from the sensor is sent as output data to either existing detectors or to a digital counter (also supplied). When the pre-set value is reached the stroke counter can be shut down with, for example, a solenoid valve.

The stroke counting system is available in five options:

- SC1 – Stroke sensor (NAMUR type) also for explosion-proof zones
- SC2 – Stroke counting system complete with sensor and counter
- SC3 – Stroke counting system complete with sensor, counter and controller for explosion-proof zones
- SC4 – Pneumatic stroke counting system with pressure transmitter
- SC5 – Pneumatic stroke counting system with pressure transmitter and counter

In cases where only the sensor is required (code SC1), it has to be connected to an existing controller with a Namur type inlet. For explosion-proof applications, the stroke counting option requires an intrinsically safe controller (code SC3), which has to be installed between the sensor and counter. The wiring diaphragm and technical data is supplied with the electric units. The controllers have to be installed in a suitable cabinet.



Flange connections (PN10 option)

This option offers the possibility to use flange connectors according to DIN/PN10. The inlet/outlet flange connections have thread bushings made of stainless steel. The attached O-rings are inserted into the grooves of the manifolds to improve sealing before connecting the pump.

- F1 – Flange connection PN 10 with EPDM O-ring
- F2 – Flange connecton PN 10 with NBR O-ring
- F3 – Flange connection PN 10 with FEP/FPM O-ring



Split connections (S options)

All pump models can be fitted with split connections (code S).

The pump can be converted from a standard double-action air-driven diaphragm pump into a unit with two single chambers. The suction and discharge connection are replaced by a split sleeve with a separate suction and discharge for both chambers. Both chambers are independent and by having them with the same drive it means there can be two media streams in a 1:1 ratio.



Diaphragm monitoring (DM options)

Although DELLMECO diaphragms are designed for optimum service and maximum lifespan, regular maintenance must be included as part of the service programme. This is called 'preventive maintenance planning' (PMP). However, for increased security in sensitive applications, any pump failure from, for example, the media leaking into the pump central housing can be simply and effectively prevented by installing a DELLMECO diaphragm monitoring system.

A capacitive diaphragm sensor is mounted in the pump's exhaust muffler and monitors any media in proximity to the sensor. Thus, immediate remedial actions can be taken.

The diaphragm monitoring system is available in two options:

- DM1 – Diaphragm sensor (NAMUR type) also for explosion-proof zones
- DM2 – Diaphragm monitoring system complete with sensor and controller

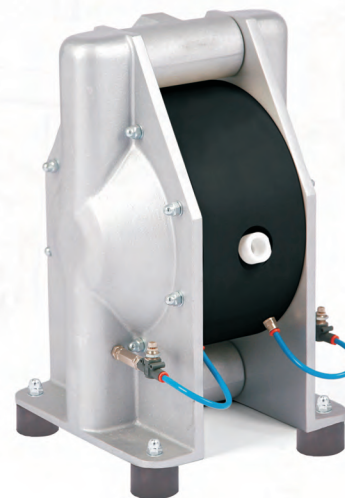

Powder pumps (P options)

DELLMECO pumps can also be used to transfer dry powders more quickly, cleanly and at a fraction of the cost than many other systems.

Key features:

- replaces manual powder transfer processes
- reduces airborne contamination
- transfers powders directly and in a closed system
- economical and simple – the opposite of large, complex system
- portable – can be moved from site to site

Applications for transferring powders up to 800 kg/m³ (50lb/ft³).

A reliable, efficient and trouble-free transfer of powders including:

- various types of dries food
- limestone
- pharmaceuticals
- talcum
- expanded mica
- silicones and silicas
- carbon black
- acrylic resins



Heating/cooling jacket (HJ options)

The heating/cooling jacket is used when the pumped media has to maintain a specific high or low temperature, throughout the pumping process. A heating or cooling medium is continuously circulated and the jacket also covers all the wetted parts of the pump.

This option is available for all Hygienic and Industrial (AISI 316) Pump Series.



Pump trolley (T options)

Make your DELLMECO pump mobile. The trolley option is available for all pump sizes.



Drum pumps (D options)

DELLMECO drum pumps are available in both standard and conductive PE, PTFE, aluminium and AISI 316L for optimum media compatibility.

The sizes range up to 1" and they can work with media of different viscosities.

Converting 3/8", 1/2", 3/4" or 1" plastic or metal pumps to a drum or real application is easy. The adaptor kits are constructed of chemically resistant materials to handle any job. And the drum pipe assembly also comes complete with all the hardware needed. Simply attach the adaptor to the drum and then fix the pump with the pipe connected into the drum.

The standard length of drum pipe is 1.0 , or 1.2 m, but orders can be made to fit any container size.



Pneumixers

Pneumixer allows the pump to be used as a mixer (circulation pump), or – thanks to the re-circulating and discharge ball valves setting – as a combination of both (mixing and pumping at the same time). With this ingenious system there is no need for rolling, shaking or pumping to mix the media. Valuable time and costs are thus saved whilst waste and mess are avoided.

Available in stainless steel AISI 316L (or PP for Plastic Pumps, without ATEX).

Mixing mode

The discharge valve is closed and the re circulation valve opened to allow the media to mix in the container.

Transfer mode

To both mix and pump the media out of the container the discharge valve is opened and the re-circulation valve partially opened.

The length of pipe can be ordered to fit any container size.

ACTIVE PULSATION DAMPENERS



PLASTIC



METAL



HYGIENIC

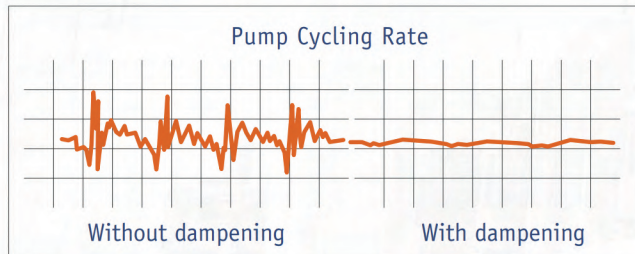

Maximum operating pressure: 8 bar

Maximum operating temperature:

PE dampener housing: 70°C

PTFE dampener housing: 120°C (with TFM diaphragm)

METAL dampener housing: 120°C (with TFM diaphragm)

1. External system

- Quality standard TÜV Rheinland, ISO 9001:2015
- ATEX certificate
- Compliance with EU Regulations and Directives
 - * for materials, products and environmental
- FDA (USA)
- 3A certification

2. Internal system

- DELLMECO QA/QC system
 - * each pump vigorously tested before delivery
 - * all distributors encouraged to have 'at least equivalent' technical support



We are always ready to help you and answer your questions

Address:

Swierkowa 2 St.,
83-330 Glinicz, Poland

Phone:

+48 532 720 222

Email:

office@dellmeco.com

Our Distributors:

Australia, Austria, Belgium, Brazil, Bulgaria, China, Czech Republic, Finland, France, Germany, Greece, Hungary, India, Italy, Japan, Korea, Latvia, Lithuania, Malaysia, Netherlands, New Zealand, Poland, Romania, Singapore, Slovakia, South Africa, South Korea, Sweden, Switzerland, Taiwan, Turkey, Ukraine, United Kingdom, USA, Vietnam.

For more information visit our website:

www.dellmeco.com



Dellmecco®

www.dellmecco.com